

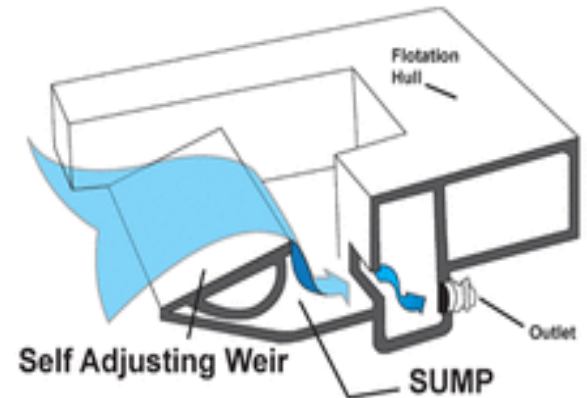

Floating Weir Skimmer (FWS) Model's FWS00A32 and FWS00A52 Series

Floating Flow Control Weir Skimmer

This skimmer starts off with the sump filled with water, which floats the weir to the closed position. As fluid is pumped from the skimmer sump, the buoyant flow control weir, automatically self adjusts...dropping and allowing an equal amount of fluid (1/8" to 2") to flow across the weir / waterfall and into the sump. The FWS is dead simple, rugged, reliable and always skims the surface, powered by the pump (or gravity drained) oily water moving across the weir/waterfall carrying the floaters with it and into the sump. Works with any pump that can pull suction. The FWS works with any pump that can pull suction.



The Skimoil FWS00A32 and FWS00A52 Skimmers are rugged, compact and portable for operation in sumps, tanks, pits and separators. Able to fit through a 24" man-way access, the FWS00A52 with only one moving part is ideal for in-tank operations with the unique automatically self adjusting flow control weir, eliminating manual adjustments. When powered by and operated by an adjustable flow rate pump, the flow rate can be adjusted to give greater surface influence and recovery of surface oil and floaters with less underlying water.

With only one moving part the FWS is ideal for closed tanks and limited access areas.

Only one moving part / Automatically self adjusting

Model No. (Material)	Flow Rate (Maximum)	Outlet Size (Camlock)	Weir Width	Dimensions	Weight
FWS00A32 (ABS IND. POLYMER)	5-58 GPM	1.5"	8"	20"X 12" X 6"	8 LBS
FWS00A52 (STAINLESS STEEL)	5-38 GPM	1.5"	7"	21"X 15.5" X 9"	25 LBS

Available in flow rates from 1 to 1500 GPM

Ideal for in-tank or limited access surface skimming

Note: All skimmers can be furnished as systems, complete with pumps and hoses. All metal skimmers can be built in a variety of alloys for corrosion resistance Ask?

All FWS have rear (horizontal) male camlock couplers, but our FWS00A32 and FWS00A52 ABS skimmers also have a top (vertical) 1.5" outlet that makes skimming easier when working the skimmer from above. The optional controller package (extension pole set) with suction wand hooks right to the top outlet and let's you move the FWS right into the oil with the extension pole. The controller package hooks right to your pump suction and puts the suction valve in your hands for extreme control.



Typical In-Tank Applications

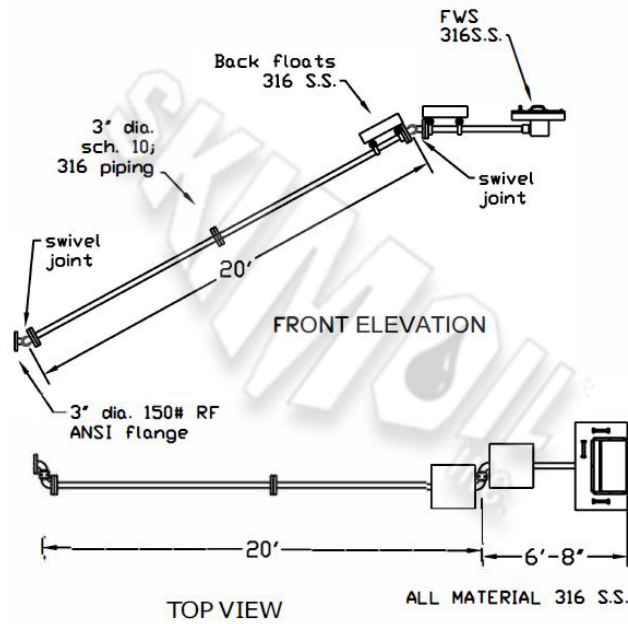

TYPICAL IN-TANK SWING-ARM SYSTEM

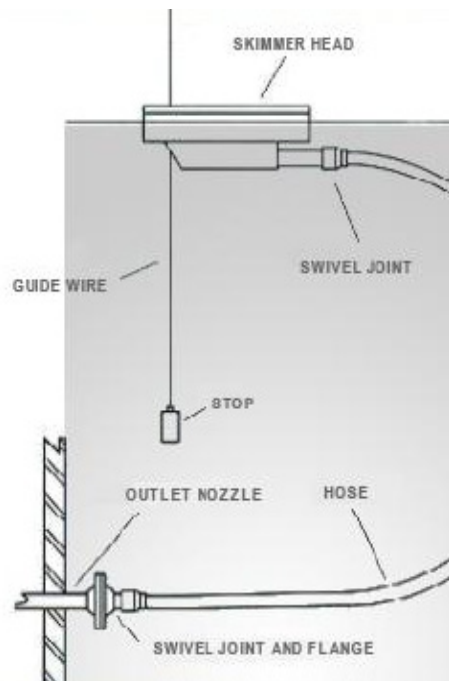

TYPICAL FLEX HOSE SYSTEM/DEPLOYMENT

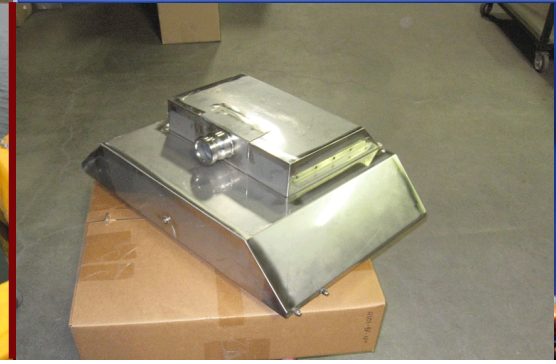

Typical Hose Connections

Typical Hose Connected Applications

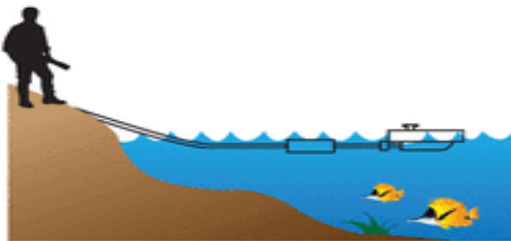

Figure 1. Floating Hose (A)

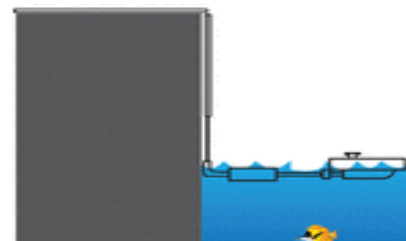

Figure 2. Floating Hose High Rise (B)

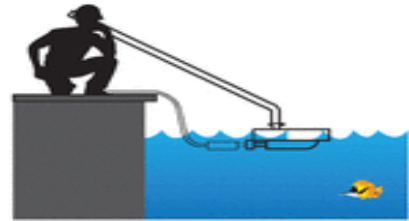
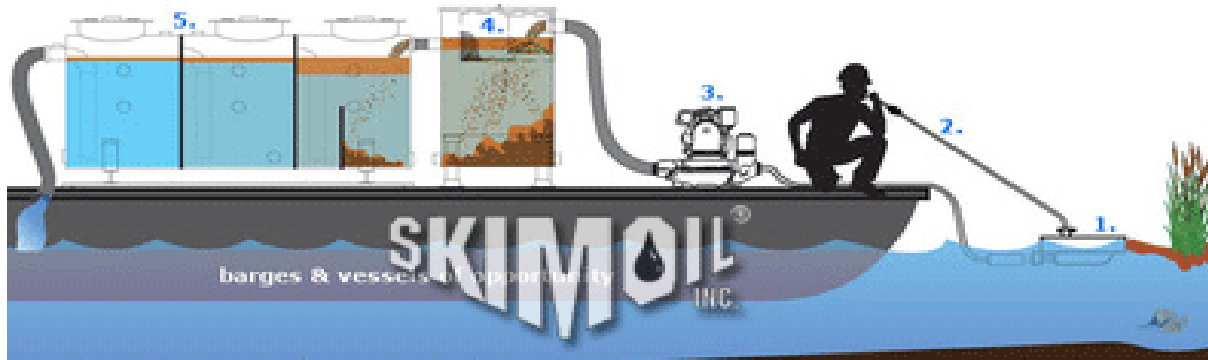

Figure 3. Manual Control System (A)



Figure 4. Manual Control System (B)

Skimoil™ GulfSHOT Skimmer & Separator System for Coastal Workboats & VOP



1. skimmer 2. control wand & suction valve 3. pump or suction system 4. knock-out strainer 5. knock-out interceptor separator

We build systems to specifically address your problem through the use of our specialty, existing, unique and innovative industrial technologies or equipment that can be used off the shelf or modified, configured or otherwise packaged, to fit your specific needs.

Give SkimOIL a call and let us build a system for your application!